

INSTRUCTION MANUAL

ProAir™ **Air Conditioner** *CR23 Model*



McLean[®]
COOLING TECHNOLOGY

A Pentair Company

*Protecting Electronics.
Exceeding Expectations.™*

McLean Cooling Technology
11611 Business Park Blvd N
Champlin, MN 55316 USA
Tel 763-323-8200
Fax 763-576-3200

www.McLeanCoolingTech.com

10-1008-163-Rev. 10

ProAir CR23

Instruction Manual

TABLE OF CONTENTS

Receiving the Air Conditioner	1
Handling and Testing the Air Conditioner	1
Installation	2
System Controls	2
Design Data, Model Drawing	3
Components List	4
Wire Diagrams	5
Temperature Control	7
Principles of Operation	7
Maintenance	7
Trouble Shooting	9
McLean Cooling Technology Warranty	11

NOTE: Some of the information in this manual may not apply if a special unit was ordered. If additional drawings for a special unit are necessary, they have been inserted. Contact McLean Cooling Technology if further information is required.

RECEIVING THE AIR CONDITIONER

Inspect the air conditioner. Check for concealed damage that may have occurred during shipment. Look for dents, scratches, loose assemblies, evidence of oil, etc. Damage evident upon receipt should be noted on the freight bill. Damage should be brought to the attention of the delivering carrier -- NOT to McLean Cooling Technology -- within 15 days of delivery. Save the carton and packing material and request an inspection. Then file a claim with the delivering carrier.

McLean Cooling Technology cannot accept responsibility for freight damages; however, we will assist you in any way possible.

HANDLING & TESTING THE AIR CONDITIONER

If it is necessary to place the air conditioner in a horizontal position after unpacking, be certain it is placed in an upright, vertical or mounting position for a minimum of five (5) minutes before operating.

Never attempt to operate the air conditioner while it is horizontal or on its side, back or front. The refrigeration compressor is filled with lubricating oil. Running the compressor without oil in the lower part of the housing will cause permanent damage to the air conditioner. This also voids the warranty.

TEST FOR FUNCTIONALITY **BEFORE** MOUNTING THE AIR CONDITIONER TO THE ENCLOSURE.

Refer to nameplate for proper electrical current requirements, then connect power cord to a properly grounded power supply. Minimum circuit ampacity should be at least 125% of the amperage shown in the design data section for the appropriate model. No other equipment should be connected to this circuit to prevent overloading.

Operate the air conditioner for five (5) to ten (10) minutes. No excessive noise or vibration should be evident during this run period. The condenser blower (ambient air), the evaporator blower (enclosure air), and the compressor should be running.

Condenser air temperatures should be warmer than normal room temperatures within a few minutes.

The compressor is provided with automatic reset thermal overload protection. This thermo-switch is located and mounted inside the plastic enclosure clipped to the compressor. The switch operates when the compressor overheats due to clogged or dirty inlet air filter or if ambient air temperatures exceed nameplate rating or if enclosure dissipated heat loads exceed the rated capacity of the air conditioner. The thermal overload switch will actuate and stop compressor operation. The blowers will continue to operate and the compressor will restart after it has cooled to within the thermal overload cut-in temperature setting.

INSTALLATION

Step 1: Inspect air conditioner. Verify functionality before mounting the air conditioner, see Handling & Testing the Air Conditioner on page 1.

Step 2: Using the cutout dimensions shown in this manual, prepare the air “IN” and air “OUT” openings, and mounting bolt hole pattern for the enclosure.

Step 3: Using the gasket kit provided, install gaskets to air conditioner. See gasket kit illustration in this manual for proper location.

Step 4: Mount air conditioner on enclosure using mounting bolts and washers provided to secure unit to enclosure. Allow unit to remain upright for a minimum of five (5) minutes before starting. Caution: Air conditioner must be in upright position during operation.

Step 5: Refer to top of nameplate for electrical requirements. Connect the power cord to a properly grounded power supply. Use of an extension cord is not recommended. Electrical circuit should be fused with slow blow or HACR circuit breaker.

Step 6: When the unit is equipped with an automatic temperature controller, the controller is preset at the factory for your convenience and should not require adjustment.

SYSTEM CONTROLS

Level I Temperature Controller

The Level I controller is located inside the air conditioner. To adjust, disconnect power to the air conditioner. Open the front panel by loosening the front panel screw. Refer to figure 2 (page 4) to locate the controller. Turn the controller adjustment screw slot counter-clockwise to increase and clockwise to decrease the temperature set point (see figure 1). The thermostat cooling setpoint is indicated by the alignment of the adjustment screw slot with the dial decal. After completing adjustment, close the front panel and tighten the front panel screw. Restore power to the air conditioner for operation.

Level II and III Temperature Controller

The Level II and III controller is mounted on the air conditioner front panel and is factory set for standard operation. All operating parameters are programmable for custom applications. Refer to the Level II and III programming and Operating Instruction Manual, 10-1008-161 (standard) or 10-1008-162 (low ambient).

Figure 1

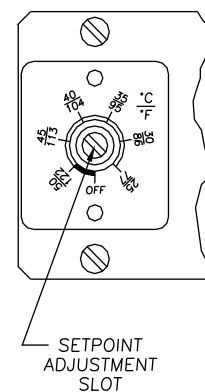

ProAir CR23

1600 BTU/Hr. (469 Watts)

H x W D: 23" (70584 x 10" (254) x 8.75" (222)

Model	Voltage	Hz	Phase	BTU/Hr @		Amps @		MAX Amb Temp °F/°C	Shipping Weight Lbs/Kgs	
				131°F/131°F	131°F/131°F	131°F/131°F	95°F/95°F			
CR23-0216-GXXX	115	50/60	1	1400/1600	131°F/131°F	4.1/4.5	1500/1700	3.8/3.6	131/55	57/26
CR23-0226-GXXX	230	50/60	1	1400/1600	131°F/131°F	2.2/2.2	1500/1700	2.1/1.8	131/55	57/26

-XXX will be replaced with a three-digit number designating all desired options. Consult the factory for specific model numbers.

CR23 Model Drawing

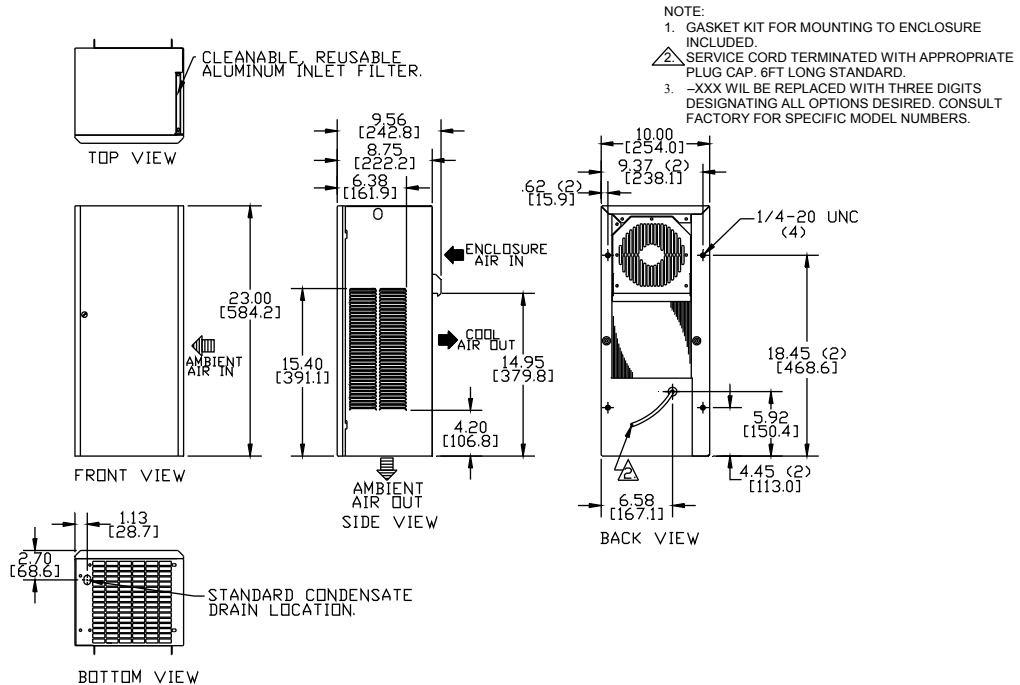

CR23 Mounting Gasket Kit

DESIGN NOTES:

- GASKET KIT INCLUDED. APPLY GASKET TO REAR OF AIR CONDITIONER BEFORE MOUNTING ON ENCLOSURE.
- SERVICE CORD TERMINATED WITH APPROPRIATE PLUG CAP.
- MILLIMETER DIMENSIONS [] ARE FOR REFERENCE ONLY; DO NOT CONVERT TO INCH DIMENSIONS.
- ALLOW AT LEAST 4" INLET AND 6" OUTLET CLEARANCE FOR PROPER AMBIENT AIR FLOW. ALLOW 20" ABOVE FILTER FOR REMOVAL.

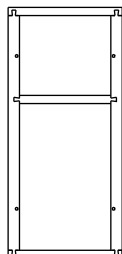

MOUNTING GASKET KIT
PART NO. 23-2000-00 AS APPLIED TO
REAR OF CR23.

CR23 Mounting Cutout Dimension

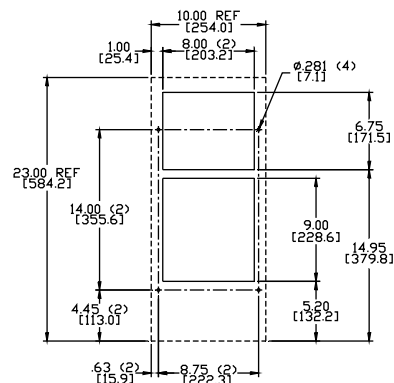

CUT-OUT NOTES:

- DASH LINES REPRESENT AIR CONDITIONER.
- CUT-OUT DIMENSIONS FOR STANDARD PRODUCT ONLY.

CR23 Components List (Table A)

Part Description	115 Volt	230 Volt
Blower, Condenser	12-1012-01	12-1012-02
Blower, Evaporator	12-1012-01	12-1012-02
Capacitor, Compressor, Start/Run	N/A	N/A
Compressor	10-1016-61 SP	10-1026-71 SP
Thermal Overload, Compressor	10-1007-19	10-1007-58
Filter, Air, Reusable	23-2004-00	23-2004-00
Thermostat, SPST, 55-100F	10-1061-16	10-1061-16
Mounting Gasket Kit	23-2000-00	23-2000-00
Relay, Compressor	N/A	N/A
Power Cord	52-6035-15	52-6035-74

Optional Parts (Table B)

Optional Part Description	115 Volt	230 Volt
Electric Heat Element	10-1038-40	10-1038-43
Electric Heat Limit Switch	10-1033-01	10-1033-01
Level II/III Transformer	10-1006-94	10-1006-93

Part	Description	Part No.
1	Condenser Coil	23-2001-00
2	Fan Pan	23-2003-00
3	Condenser Blower	See Table A
4	Evaporator Coil	23-2002-00
5	Air Filter	23-2004-00
6	Compressor	See Table A
7	Cool Relay (Lev. II/III only)	10-1005-21
8	Transformer (Lev. II/III only)	See Table B
9	Heat Relay (Lev. II/III with Electric Heat only)	10-1005-21
10	Temperature Controller	Consult Factory
11	Electric Heat Element & Limit Switch	See Table B
12	Terminal Block	10-1003-03
13	Expansion Valve	Consult Factory
14	Evaporator Blower	See Table A
15	Filter Drier	52-6028-03
16	Compressor Thermal Overload	See Table A
17	Mounting Gasket Kit	23-2000-00
18	Power Cord	See Table A
19	Capillary Tube	99-0360-35

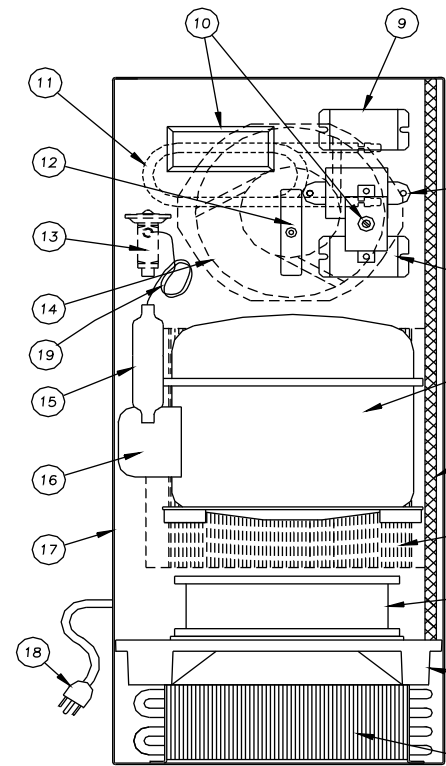
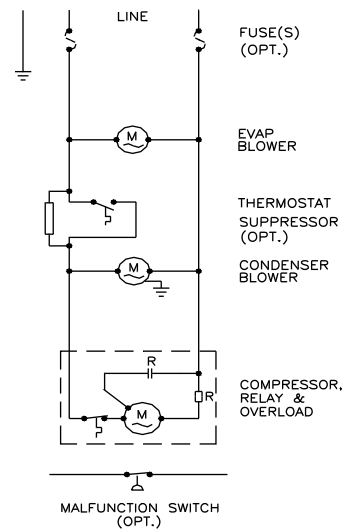
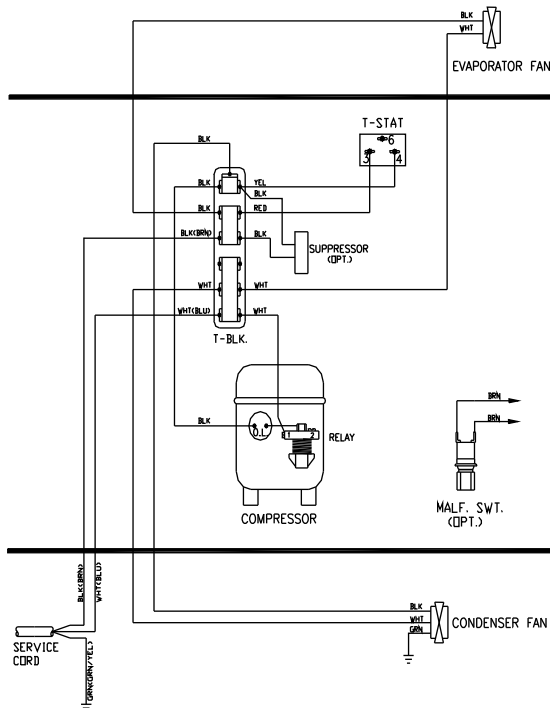

Figure 2

CR23 Wire Diagram, Level 1



ELECTRICAL SCHEMATIC

CR23 Wire Diagram, Level 1 with Electric Heat

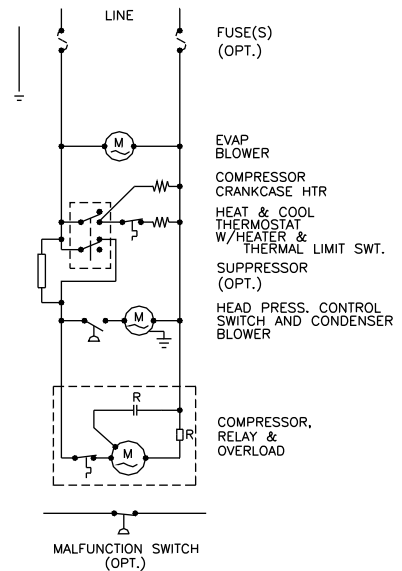
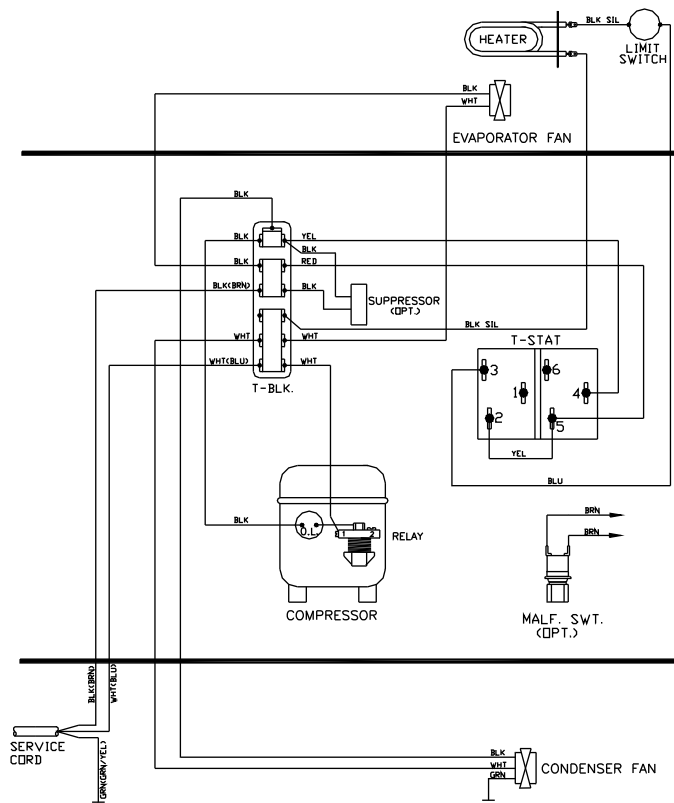

ELECTRICAL SCHEMATIC

NOTE: For voltage, hertz, and options not shown in this manual, refer to the wiring diagram attached to the unit.

CR23 Wire Diagram, Level II & III

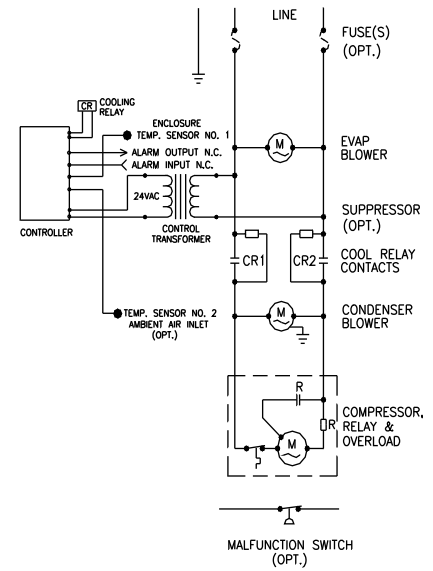
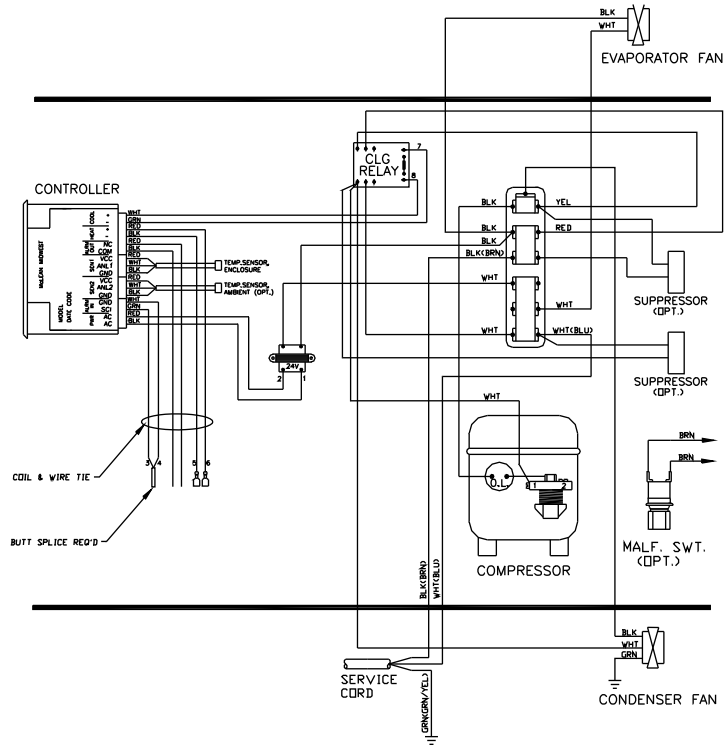

ELECTRICAL SCHEMATIC

CR23 Wire Diagram, Level II & III with Electric Heat

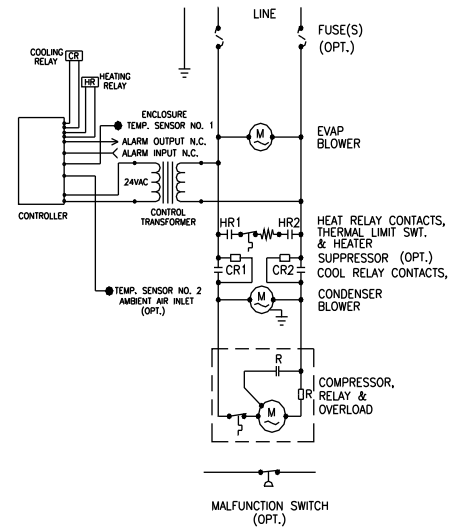
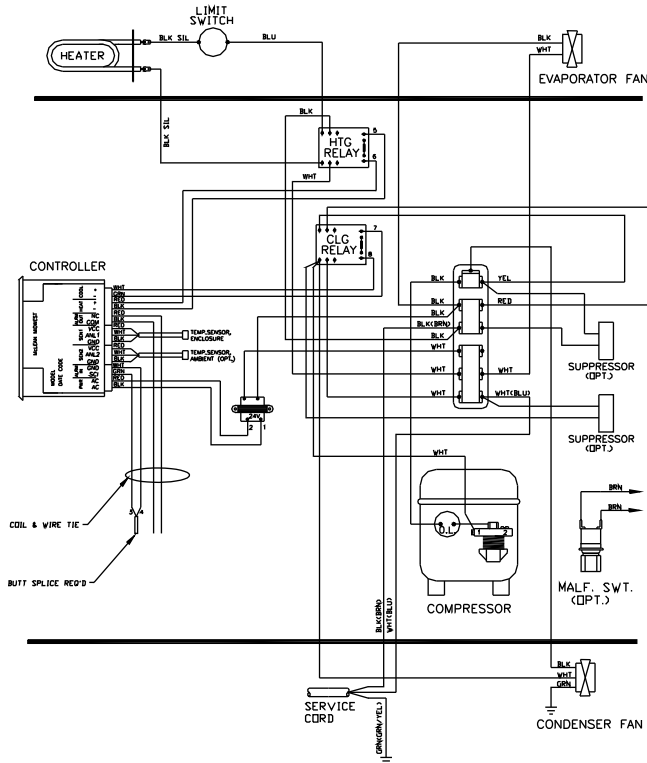

ELECTRICAL SCHEMATIC

NOTE: For voltage, hertz, and options not shown in this manual, refer to the wiring diagram attached to the unit.

TEMPERATURE CONTROL

The electromechanical thermostat is factory preset to 75°F/23°C. To change the temperature setting, remove the nylon plug from the back face of the unit. Use a standard screwdriver to adjust thermostat. For cooler temperatures turn clockwise, for warmer temperatures turn counterclockwise.

PRINCIPLES OF OPERATION

If electrical power to the air conditioner is interrupted and reapplied immediately, (within 3 to 5 seconds), the compressor may not restart due to the high back pressure of the compressor. It takes a minimum of one (1) minute after shut-down for the compressor suction and discharge pressures to equalize in order for the air conditioner to restart.

Operating the air conditioner below the minimum ambient temperature or above the maximum ambient temperatures indicated on the nameplate voids all warranties.

It is recommended that the warranty section of this manual be read in order to familiarize yourself with parameters of restricted operation.

The moisture that the enclosure air can contain is limited. If moisture flows from the drain tube continuously this can only mean that ambient air is entering the enclosure. Be aware that frequent opening of the enclosure's door admits humid air which the air conditioner must then dehumidify.

MAINTENANCE

Compressor

The compressor requires no maintenance. It is hermetically sealed, properly lubricated at the factory and should provide years of satisfactory operating service.

Should the refrigerant charge be lost, recharging ports (access fittings) on the suction and discharge sides of the compressor are provided for recharging and/or checking suction and discharge pressures.

Under no circumstances should the access fitting covers be loosened, removed or tampered with.

Breaking of seals on compressor access fittings during warranty period will void warranty on hermetic system.

Recharging ports are provided for the ease and convenience of reputable refrigeration repair service personnel for recharging the air conditioner.

Inlet Air Filter

Proper maintenance of the inlet air filter, located behind the right side panel, will assure normal operation of the air conditioner. If filter maintenance is delayed or ignored, the maximum ambient temperatures under which the unit is designed to operate will be decreased.

If the compressor's operating temperature increases above designed conditions due to a dirty or clogged filter (or plugged condenser coil), the air conditioner's compressor will stop operating due to actuation of the thermal overload cut-out switch located on the compressor housing. As soon as the compressor temperature has dropped to within the switch's cut-in setting, the compressor will restart automatically. However the above condition will continue to take place until the filter or coil has been cleaned. It is recommended that power to the air conditioner be interrupted intentionally when abnormally high compressor operating temperature causes automatic shut-down of the unit.

The above described shut-down is symptomatic of a clogged or dirty filter, thus causing a reduction in cooling air flow across the surface of the compressor and condenser coil.

Do not run the air conditioner for extended periods of time with the filter removed. Particles of dust, lint, etc., can plug the fins of the condenser coil which will give the same reaction as a plugged filter. The condenser coil is not visible through the filter opening, so protect it with a filter.

Continued operation under the above conditions can and will damage and shorten compressor life. The air conditioner is available with an easily removable inlet filter to facilitate necessary cleaning. There should be no reason to neglect this necessary maintenance.

How To Remove, Clean or Install a New Inlet Air Filter

RP aluminum washable air filters are designed to provide excellent filtering efficiency with a high dust holding capacity and a minimum amount of resistance to air flow. Because they are constructed entirely of aluminum they are lightweight and easy to service. Optimum filter performance is maintained by recoating the filters after washing with RP Super Filter Coat adhesive. To achieve maximum performance from your air handling equipment, air filters should be cleaned on a regular basis.

The inlet air filter is located behind the right side panel. To access filter, pull from slot in top cover. The filter may now be cleaned or new filter installed.

Cleaning Instructions:

1. Flush the filter with warm water from the exhaust side to the intake side. DO NOT USE CAUSTICS.
2. After flushing allow filter to drain. Placing it with a corner down will assure complete drainage.
3. Recoat the filters with RP Super Filter Coat adhesive. When spraying filter do so from both sides for maximum concentration of adhesive.

Condenser and Evaporator Fans

Fan motors require no maintenance. All bearings, shafts, etc. are lubricated during manufacturing for the life of the motor.

If the condenser fan motor (ambient fan) should fail, it is not necessary to remove the air conditioner from the cabinet or enclosure to replace the fan. The condenser fan is mounted on its own bulkhead and is easily accessible by opening the front cover.

Caution: Operation of the air conditioner in areas containing airborne caustics or chemicals can rapidly deteriorate filters, condenser coils, fans and motors, etc. Contact McLean Cooling Technology for special recommendations.

Refrigerant Loss

Each air conditioner is thoroughly tested prior to leaving the factory to insure against refrigeration leaks. Shipping damage or microscopic leaks not found with sensitive electronic refrigerant leak detection equipment during manufacture may require repair or recharging of the system. This work should only be performed by qualified professionals, generally available through a local, reputable air conditioning repair or service company.

Refer to the data on the nameplate which specifies the type of refrigerant and the charge size in ounces.

Before recharging, make sure there are no leaks and that the system has been properly evacuated into a deep vacuum.

TROUBLE SHOOTING

Basic Air Conditioning Trouble Shooting Check List

1. Check manufacturer's nameplate located on the unit for correct power supply.

2. Turn the power to the unit on. The evaporator (Enclosure or "COLD" air) fan should come on. Is there airflow?

YES, proceed to step # 3.

NO, possible: Open motor winding
 Stuck fan motor
 Obstructed blades

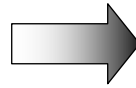

Repair or Replace defective parts.

3. Check thermostat setting? Adjust thermostat to the lowest setting. This should turn the condenser fan and the compressor on. Did condenser fan and compressor come on when the thermostat was turned on?

YES, proceed to step #4.

NO, possible: Defective thermostat

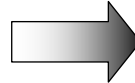

Replace part.

4. Are both fans and the compressor running? If not the unit will not cool properly.

5. Check condenser (Ambient or "HOT" air) fan for airflow. Is there airflow ?

YES, proceed to step # 6.

NO, possible: Defective thermostat
 Open motor winding
 Stuck fan motor
 Obstructed blades

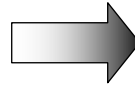

Repair or Replace defective parts.

6. Carefully check the compressor for operation - motor should cause slight vibration, and the outer case of the compressor should be warm.

YES, wait 5 minutes, then proceed to step #7.

NO, possible: Defective thermostat
 Defective capacitor
 Defective overload
 Defective relay

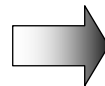

Repair or Replace defective parts.

7. Make sure the coils are clean. Then check evaporator "air in" and "air out" temperatures. If the temperatures are the same:

Possible loss of refrigerant
Possible bad valves in the compressor



Repair or Replace defective parts.

8. To check for a bad thermostat. Turn power to the unit off. Remove control box cover, place both thermostat wires onto one terminal (replace control box cover for safety). This will bypass the switch in the thermostat. Turn the power on. If both fans and the compressor come on, the thermostat needs to be replaced.

Symptoms and Possible Causes:

<u>SYMPTOM</u>	<u>POSSIBLE CAUSE</u>
Unit won't cool	<ul style="list-style-type: none">* Fans not running* Compressor not running* Compressor runs, but has bad valves* Loss of refrigerant
Compressor tries to start but won't run	<ul style="list-style-type: none">* Low line voltage at start. Should be +/-10% rated voltage* Compressor motor stuck* Bad relay* Bad overload switch* Bad run/start capacitor
Unit blows breakers	<ul style="list-style-type: none">* Under sized breaker/fuse or not time delayed* Short in system
Getting water in enclosure	<ul style="list-style-type: none">* Drain plugged* Drain tube kinked* Enclosure not sealed (allowing humidity in)

For additional technical information (ie., amp draw, pressures, temperatures) contact McLean Cooling Technology at 763-323-8200.

McLEAN WARRANTY

MCLEAN warrants that the Goods manufactured by MCLEAN will be free from defects in material and workmanship for a period of one (1) year from the date of shipment by MCLEAN, subject to the following conditions and exclusions:

- A. Conditions. All Goods must be installed and operated according to the following specifications:
1. Maximum voltage variation no greater than plus or minus 10% of nameplate nominal rating;
 2. Maximum frequency variation no greater than plus or minus 3 Hz. of nameplate nominal rating;
 3. Must not exceed minimum and maximum stated temperatures on the nameplate;
 4. Must not exceed (BTU/Hr) rating, including any heat sink as indicated on the nameplate;
 5. Refrigerant bearing Goods must not be restarted for a period of one (1) minute after intentional or accidental shut-off;
 6. The filters (if applicable) must be cleaned regularly;
 7. The Goods and any parts thereof must not be modified, unless prior written authorization is received from MCLEAN; and
 8. All Goods must be installed and grounded in accordance with all relevant electrical and safety codes, as well as the National Electric Code and OSHA rules and regulations.
 9. All Goods must be installed in a stationery application, free of vibration.

A violation of any one of these conditions shall render the warranty hereunder void and of no effect.

- B. Exclusions. This warranty shall be void if product is misapplied in any way or:
1. Buyer specified product is inappropriate for system or environment it is operating in.
 2. McLean product modified in any way without prior written authorization from McLean.
 3. Removal or modification of McLean label affixed to product without written McLean approval.

MCLEAN must be notified of a claim in writing not later than fourteen (14) days from the date when Buyer has become aware of such occurrence, or where the defect is such that it may cause damage, immediately, such notice containing a description of how the defect manifests itself. Failure to provide such prompt notice to McLean shall result in forfeiture of Buyer's rights under this warranty.

In the event of a warranty claim, Buyer is to return defective goods to McLean in accordance with McLean Return Policy. Warranty period for repaired goods remains at 1 year from shipment of original goods. McLean's sole obligation to Buyer under this warranty will be, at McLean's option:

- A. Repair or replace McLean products or parts found to be defective in material or workmanship.
- B. Issue credit for the purchase price paid by Buyer relating to such defective Goods or part.

THIS WARRANTY CONSTITUTES THE ENTIRE WARRANTY WITH RESPECT TO THE GOODS AND IS IN LIEU OF ALL OTHER WARRANTIES, EXPRESSED OR IMPLIED, INCLUDING ANY IMPLIED WARRANTY OF MERCHANTABILITY AND IMPLIED WARRANTY OF FITNESS FOR A PARTICULAR PURPOSE.

(continued on next page)

RETURN & REPAIR POLICY

McLean products that: (i) are made to order, (ii) have been modified by Buyer, (iii) have special finishes, or (iv) are determined by McLean to constitute "custom" products that cannot be returned to stock or resold to other Buyers, will not be accepted for return by McLean.

All returns require a Return Material Authorization number (RMA #), regardless of reason for return, whether it be for warranty or out of warranty repair. Returns without an RMA # will be refused by our Receiving Department. An RMA # is valid for 60 days.

A. An RMA # will be issued by our Repair Department in Champlin, MN at (763) 323-8200. Buyer should have following information available at time of RMA request:

1. Complete Model Number, Serial Number and description of damaged unit being returned.
2. Original Buyer Purchase Order number and date product was received by Buyer.
3. Quantity to be returned and a brief description of failure for each unit, if different.
4. Contact information of Buyer that must include: name of company, billing and shipping address, phone, number, fax number, freight carrier and the name and phone number of a Buyer contact who can elaborate on the claimed defect in detail.
5. Buyer must provide a Repair Purchase Order number for both warranty and out of warranty repairs. The PO will not exceed 50% of a new unit. Buyer will be notified of repair charges that exceed approved PO amount.

B. All returns to McLean must be securely packed, using original cartons if possible. All returns must have the RMA number visible on the outside of the carton. McLean is not responsible for material damaged in transit. Any refrigerant-bearing Goods must be shipped upright for return.

C. Shipping cost for all non-warranty repairs is the responsibility of the sender and must be shipped prepaid. Shipping costs for all warranty related repairs will be covered by McLean provided the goods are returned using a McLean approved carrier. If after diagnosis the product is determined by McLean not to be covered under warranty, Buyer will be responsible for all shipping charges and will be billed accordingly.

D. Non-warranty repairs are subject to a \$75 minimum analysis fee. Analysis fee will be waived if Buyer approves repair work. If approval is not received within 30 days, material will be scrapped and all shipping expenses and corresponding analysis fees will be billed to Buyer.

E. At Buyer's request, Failure Analysis can be provided by McLean for warrantable goods at no charge. Failure analysis for non-warranty repairs are subject to a \$100 per hour Engineering charge plus any other incurred testing costs.

F. All returned merchandise must be sent to the following address: McLean Midwest Corporation, 11611 Business Park Boulevard N., Champlin, MN 55316.

(continued on next page)

RETURN & REPAIR POLICY (continued from previous page)

G. Credit for accepted returns shall be at the original selling price or the current selling price, whichever is lower, less the restocking charge indicated as follows:

1. Within 60 days of invoice date - 20% of applicable selling price.
2. Within 61-120 days of invoice date - 30% of applicable selling price.
3. Within 121-180 days of invoice date - 40% of applicable selling price.
4. Beyond 180 days - subject to individual review by McLean.

If product being returned for credit requires repair or modification, the cost of any labor or material necessary to bring product into saleable condition will be deducted from credit. Buyer may not take credit against returns without prior written McLean approval.

LIMITATION OF LIABILITY. MCLEAN WILL NOT BE LIABLE UNDER ANY CIRCUMSTANCES FOR ANY INCIDENTAL, CONSEQUENTIAL OR SPECIAL DAMAGES, INCLUDING WITHOUT LIMITATION ANY LOST PROFITS OR LABOR COSTS, ARISING FROM THE SALE, USE OR INSTALLATION OF THE GOODS, FROM THE GOODS BEING INCORPORATED INTO OR BECOMING A COMPONENT OF ANOTHER PRODUCT, FROM ANY BREACH OF THIS AGREEMENT OR FROM ANY OTHER CAUSE WHATSOEVER, WHETHER BASED ON WARRANTY (EXPRESSED OR IMPLIED) OR OTHERWISE BASED ON CONTRACT, OR ON TORT OR OTHER THEORY OF LIABILITY, AND REGARDLESS OF ANY ADVICE OR REPRESENTATIONS THAT MAY HAVE BEEN RENDERED BY MCLEAN CONCERNING THE SALE, USE OR INSTALLATION OF THE GOODS

*Protecting Electronics.
Exceeding Expectations.™*

McLean Cooling Technology
11611 Business Park Blvd N
Champlin, MN 55316 USA
Tel 763-323-8200
Fax 763-576-3200



McLean[®]
COOLING TECHNOLOGY

A Pentair Company